

P			F			LTR			REVISIONS	
						DESCRIPTION			DATE	APPROVED
0	0	0	0	0	0	RLSD; NPI C86-1			3/7/86	TE <i>BZ</i>

1. ALL DIMENSIONS SHOWN ARE MAXIMUM UNLESS OTHERWISE SPECIFIED.
2. MATERIAL: BRIGHT ZINC PLATED CARBON STEEL.

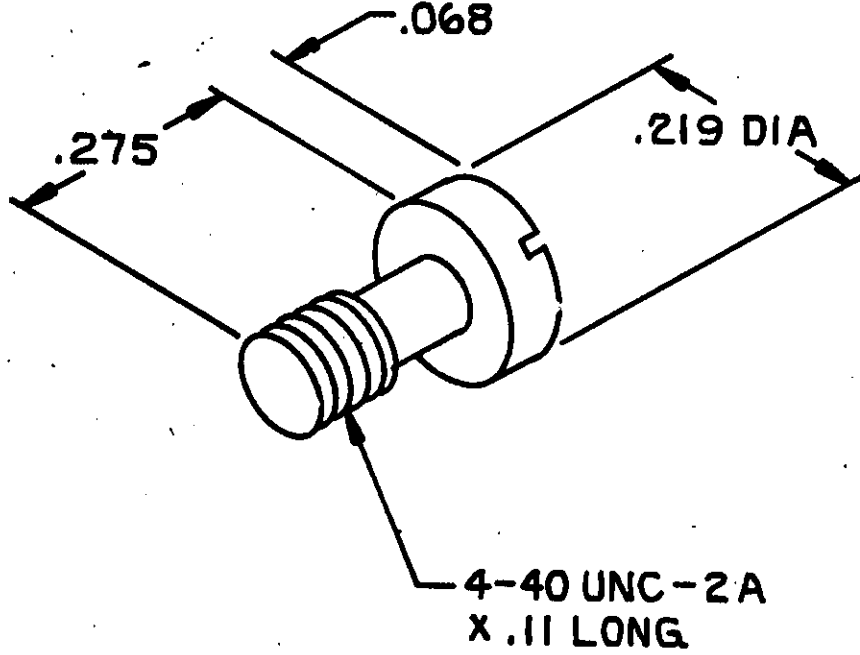

THIS DRAWING IS UNPUBLISHED. RELEASED FOR PUBLICATION
 BY AMP INCORPORATED, HARRISBURG, PA. ALL INTERNATIONAL RIGHTS RESERVED. AMP PRODUCTS MAY BE COVERED BY U.S. AND FOREIGN PATENTS AND/OR PATENTS PENDING.

BULK PACKED	554726-1
PACKAGED	PART NO

UNLESS OTHERWISE SPECIFIED DIMENSIONS ARE IN INCHES. TOLERANCES ON: DECIMALS ± = ANGLES ± =	CONTRACT NO
MATERIAL	DR <i>J. Ganty</i> 3/7/86
FINISH	CHK <i>S. Fox</i> 3-20-86
	APPD <i>B. Hutchens</i> 5/27/86
	APPD <i>B. Wilkerson</i> 5-27-86
	DSGN APPD
	OTHER APPD

AMP AMP INCORPORATED Harrisburg, Pa. 17105		
NAME SCREW, PAN HEAD, CAPTIVE, SHIELDED CHAMP		
SIZE A	FSCM NO 00779	DRAWING NO 554726
SCALE 4:1	SHEET 1 OF 1	